

D  
C  
B  
A

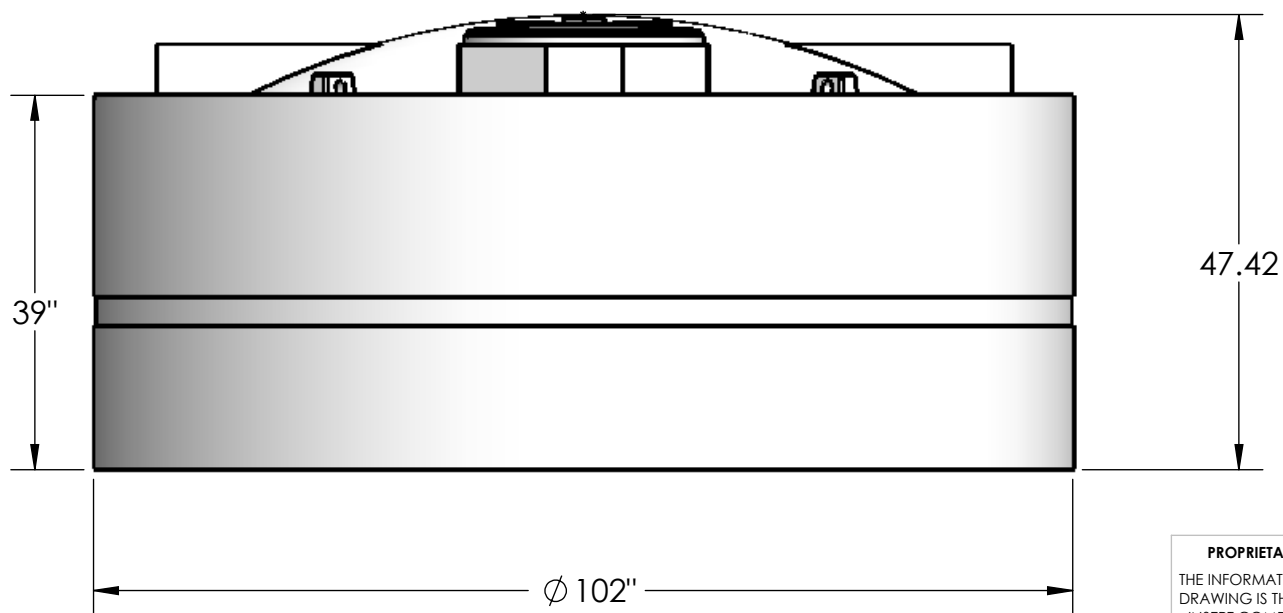
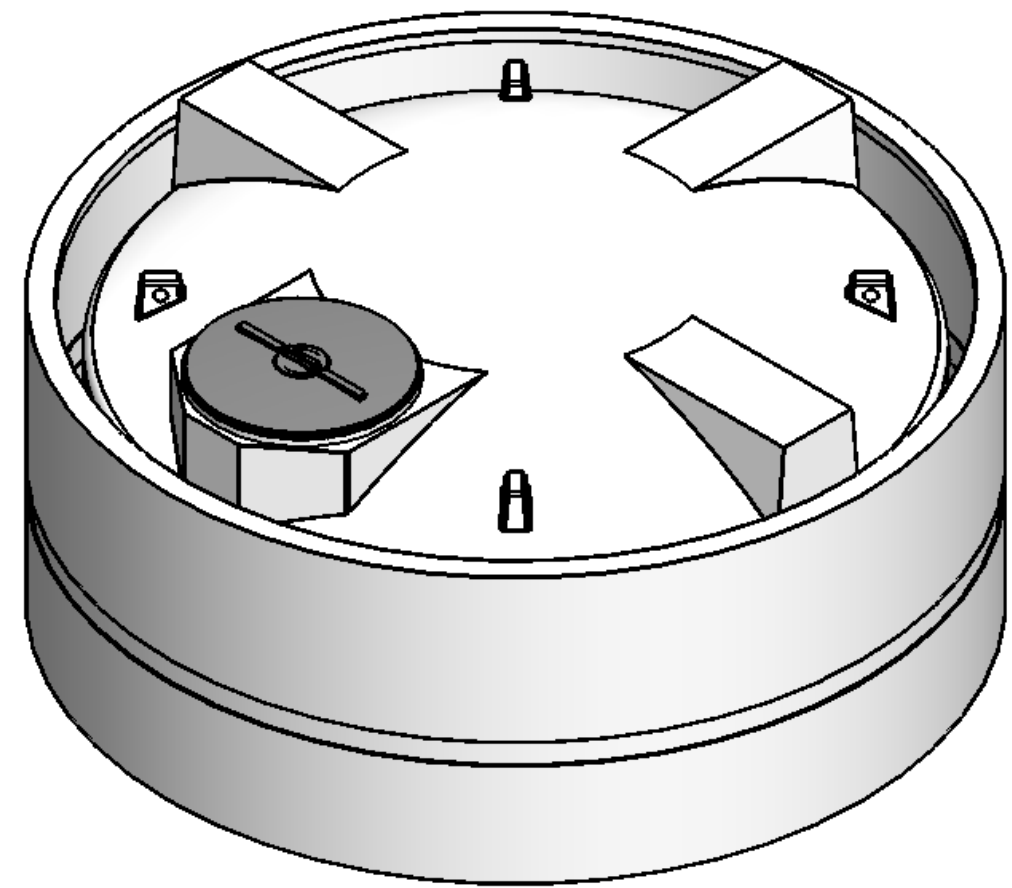
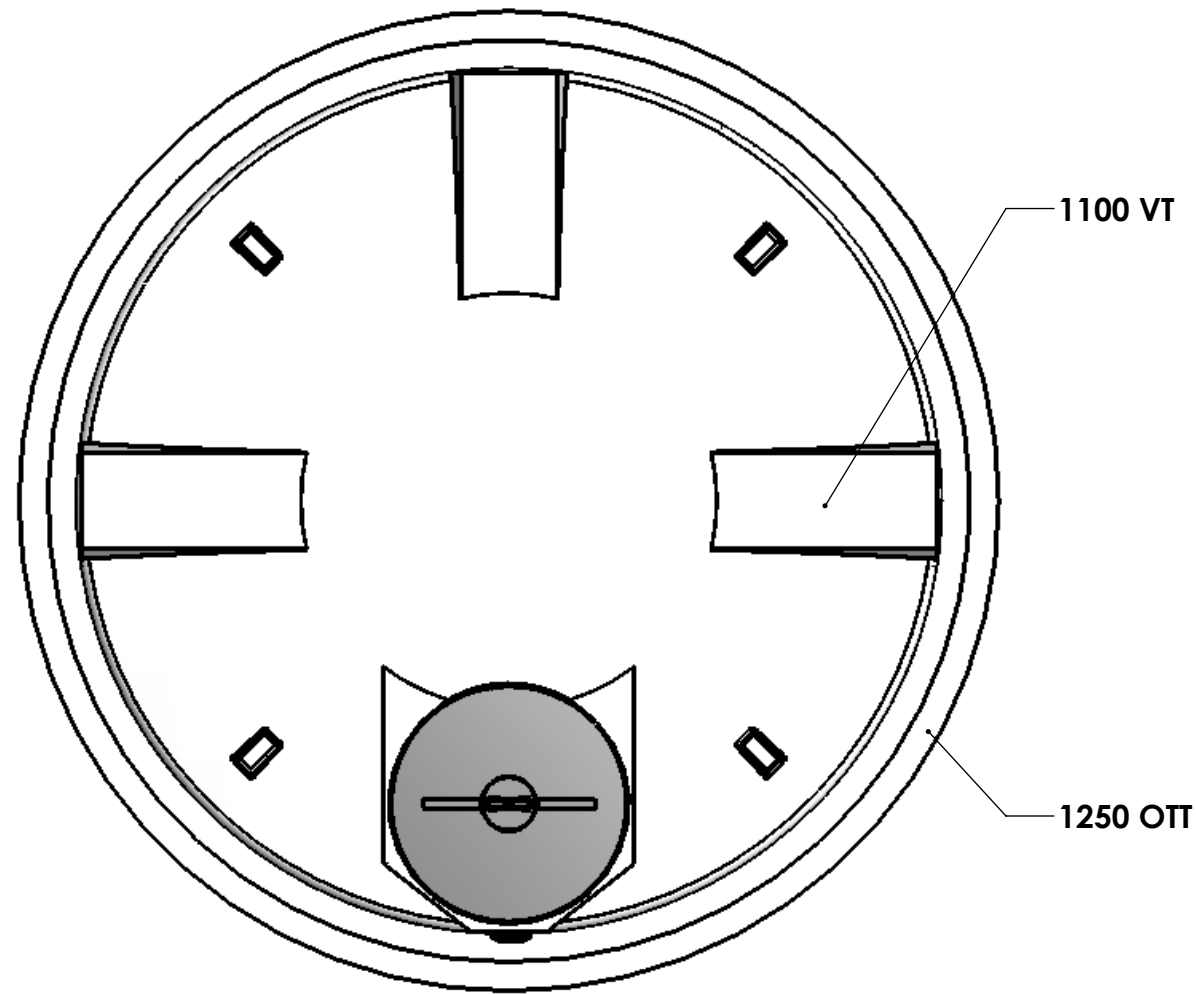

NOTES:

1. MATERIAL: PRIMARY TANK - HDPE  
CONTAINMENT - HDPE
2. PRIMARY TANK: STD. 1.5 SG.
3. CONTAINMENT: STD. 1.5 SG
4. SHIPPING WEIGHT: 305 LBS.

**PROPRIETARY AND CONFIDENTIAL**  
THE INFORMATION CONTAINED IN THIS DRAWING IS THE SOLE PROPERTY OF <INSERT COMPANY NAME HERE>. ANY REPRODUCTION IN PART OR AS A WHOLE WITHOUT THE WRITTEN PERMISSION OF <INSERT COMPANY NAME HERE> IS PROHIBITED.

		UNLESS OTHERWISE SPECIFIED:		NAME	DATE
		DIMENSIONS ARE IN INCHES		DRAWN	EBW 12-17-14
		TOLERANCES:		CHECKED	
		FRACTIONAL ±		ENG APPR.	
		ANGULAR: MACH ± BEND ±		MFG APPR.	
		TWO PLACE DECIMAL ±		Q.A.	
		THREE PLACE DECIMAL ±		COMMENTS:	
		INTERPRET GEOMETRIC TOLERANCING PER:		TITLE:	
		MATERIAL		1100 VT - 1250 OTT	
		FINISH		SIZE DWG. NO. REV	
NEXT ASSY	USED ON			B 1100 VTWC	
APPLICATION		DO NOT SCALE DRAWING		SCALE: 1:32 WEIGHT: SHEET 1 OF 1	

