

8 7 6 5 4 3 2 1

D
C
B
A

D
C
B
A

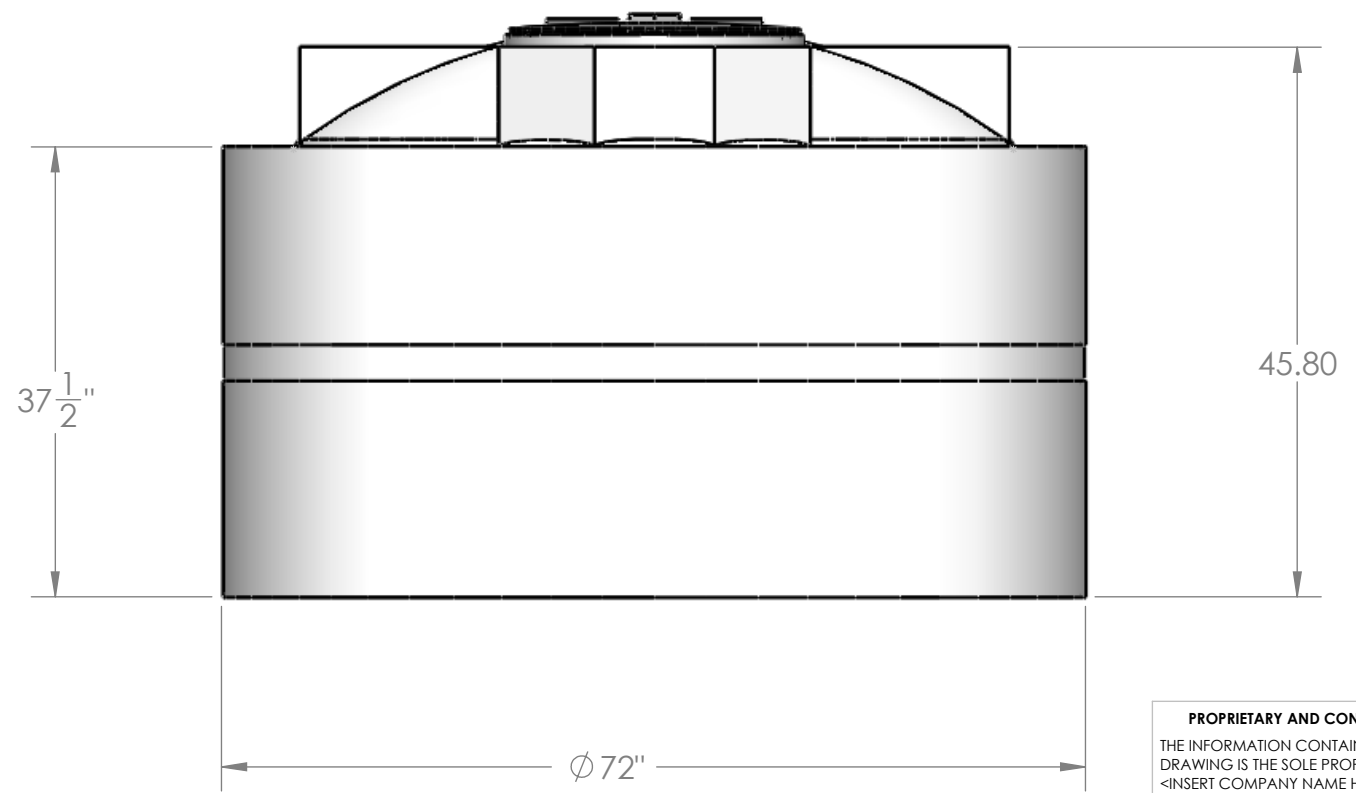
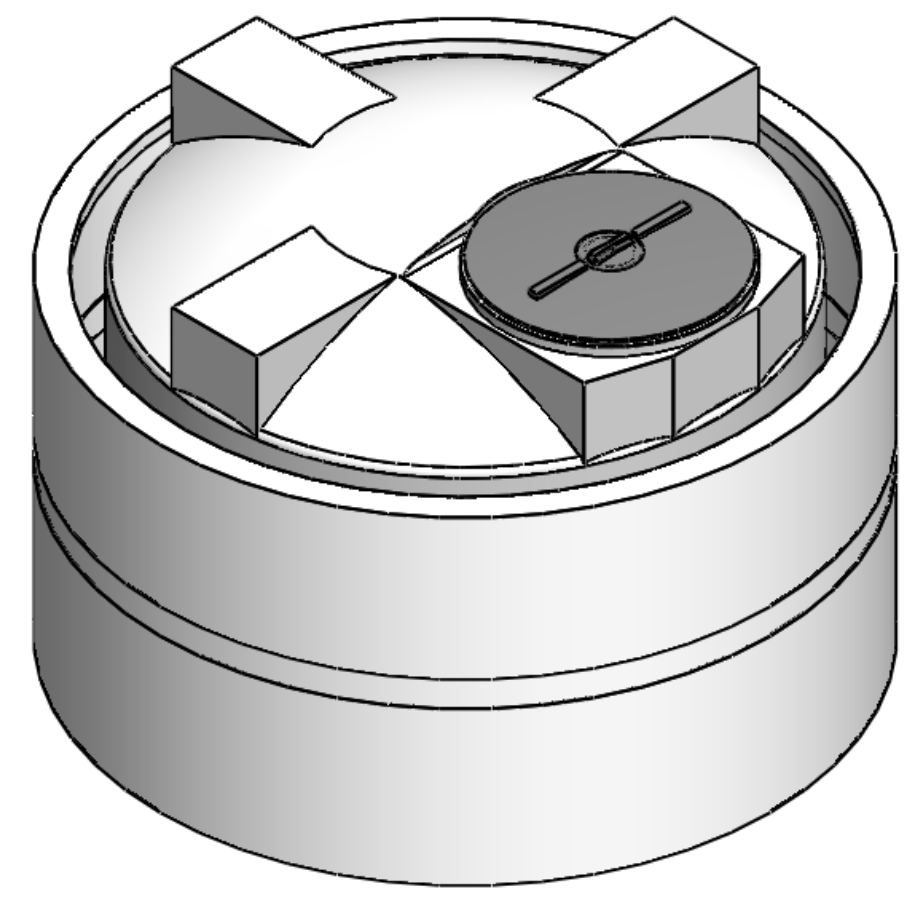
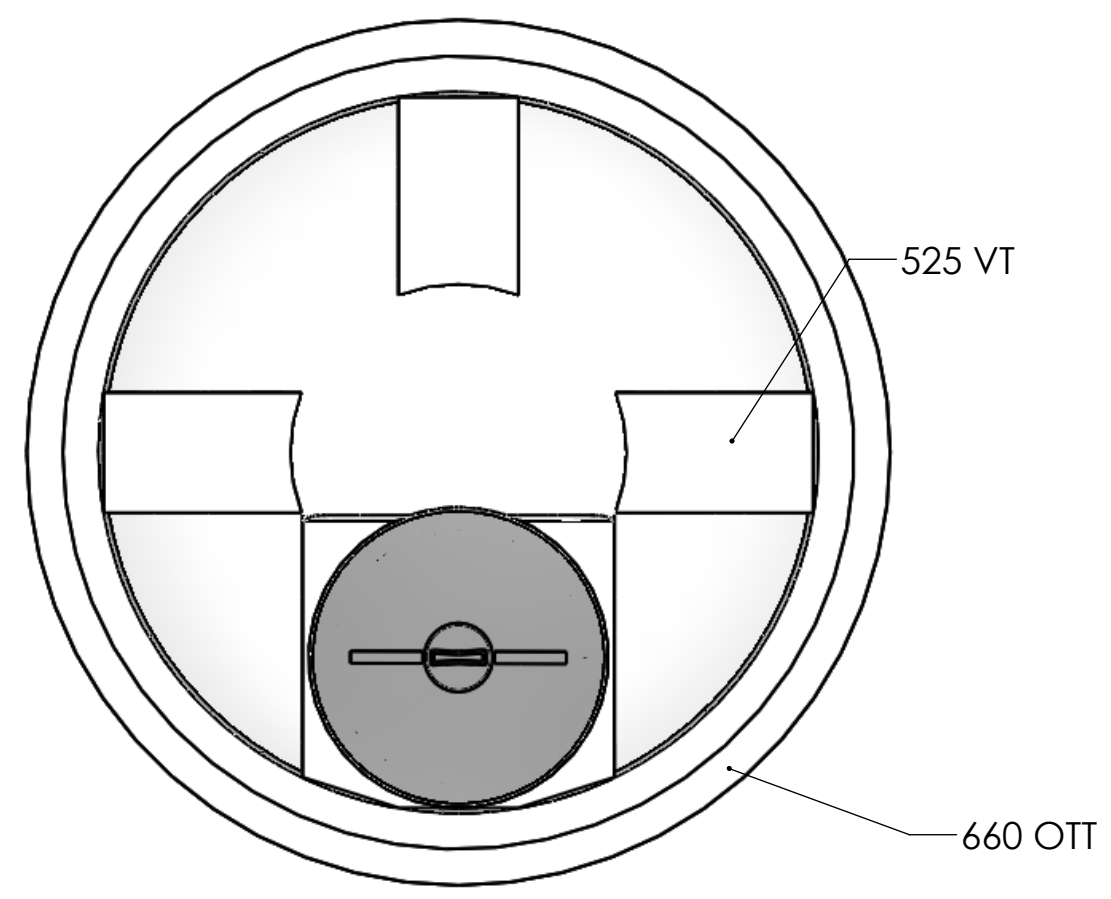

NOTES:

1. MATERIAL: HDPE
2. PRIMARY TANK: STD. = 2.0 S.G. 90 LBS
3. CONTAINMENT: STD. = 1.5 S.G. 100 LBS
4. SHIPPING WT. : 190 LBS.

PROPRIETARY AND CONFIDENTIAL
 THE INFORMATION CONTAINED IN THIS DRAWING IS THE SOLE PROPERTY OF <INSERT COMPANY NAME HERE>. ANY REPRODUCTION IN PART OR AS A WHOLE WITHOUT THE WRITTEN PERMISSION OF <INSERT COMPANY NAME HERE> IS PROHIBITED.

		UNLESS OTHERWISE SPECIFIED:		NAME	DATE	CUSTOM ROTO-MOLDING, INC.
		DIMENSIONS ARE IN INCHES TOLERANCES: FRACTIONAL ± ANGULAR: MACH ± BEND ± TWO PLACE DECIMAL ± THREE PLACE DECIMAL ±		DRAWN	1-18-11	
		INTERPRET GEOMETRIC TOLERANCING PER:		CHECKED		TITLE:
		MATERIAL		ENG APPR.		525 VT - 660 OTT
		FINISH		MFG APPR.		
NEXT ASSY	USED ON			Q.A.		SIZE DWG. NO. REV
APPLICATION		DO NOT SCALE DRAWING		COMMENTS:		B 525 VTWC
						SCALE: 1:24 WEIGHT: SHEET 1 OF 1

8 7 6 5 4 3 2 1